

FEATURES

The W610 Series filter assembly can be manifold mounted to the hydraulic system. Other port options include SAE straight thread and 4 bolt flange. Western Filter's proprietary BetaPore™ 5 layer media is offered in a variety of Pak™ designs. Five different media grades are offered down to 5.1µ(c). WF elements core collapse options range from 150 to 3000 PSI. The differential pressure indicator line is designed to work with the wide assortment of bypass valves. Thermal lockout and surge control are two key features incorporated in many of the valves.

Western Filter elements are compatible with petroleum oils, water glycol, oil/water, HWCF and synthetic fluids.

Technical Data:

Maximum Working Pressure	6000 psi (414 bar)
Fatigue Pressure Rating	3500 psi max (241 bar)
Typical Burst Pressure	20000 psi max (1379 bar)
Temperature Range	Operating
Buna N	-45°F to + 225°F (-43°C to + 107°C)
Viton	-20°F to + 250°F (-29°C to + 121°C)
Head Material	Cast Iron
Bowl Material	Steel
Weight (without elements)	
Assembly length 1	9.72 lbs. (4,4 kg.)
Assembly length 2	12.33 lbs. (5,6 kg.)
Assembly length 4	15.23 lbs. (6,89 kg.)

W610

55 gpm (208 l/min)

Replacement elements available for C-Pak™ and H-Pak™ elements

Optional manifold mounting

Wide range of indicator options

Optional mounting bracket

High collapse H-Pak™ element available for use with non-bypass applications



ACCESSORIES

Seal Kit -Buna N	P-427466-04
Seal Kit -E.P.R.	P-427466-05
Seal Kit -Viton	P-427466-06
Mounting Bracket	P-426225-01

Housing and Filter Element

Flow versus Pressure Drop

150 SUS (32 cSt.) oil with specific gravity ≤ 0.9

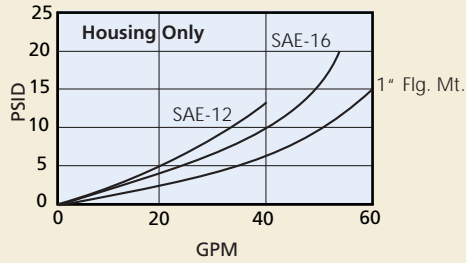

Viscosity Correction Formula

$$\Delta P \text{ Element} = \text{psid from catalog} \times \frac{\text{New Viscosity (SUS)}}{150} \times \frac{\text{New Specific Gravity}}{0.90}$$

$$\Delta P \text{ Housing} = \text{psid from catalog} \times \frac{\text{New Specific Gravity}}{0.90}$$

$$\Delta P \text{ Assembly} = \Delta P \text{ Element} + \Delta P \text{ Housing}$$

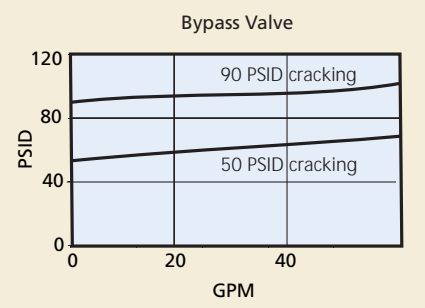
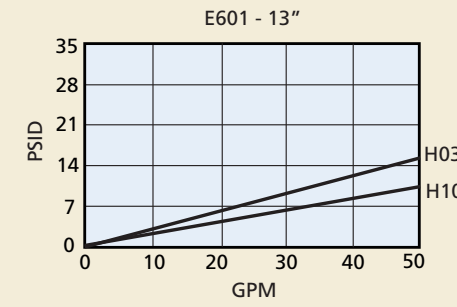
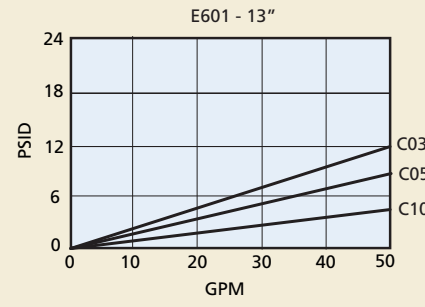
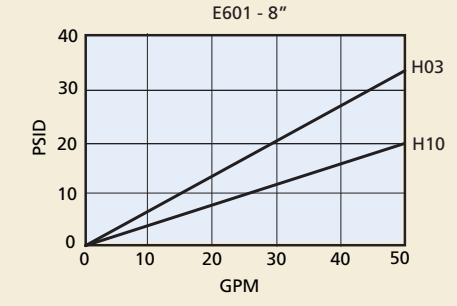
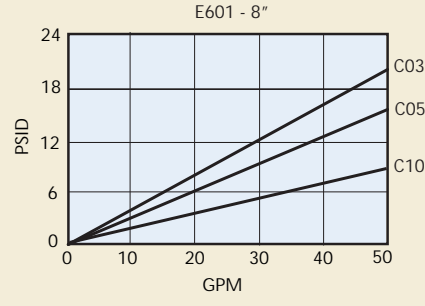
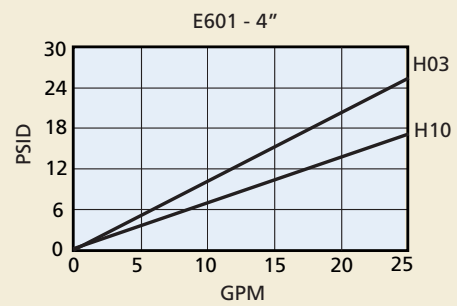
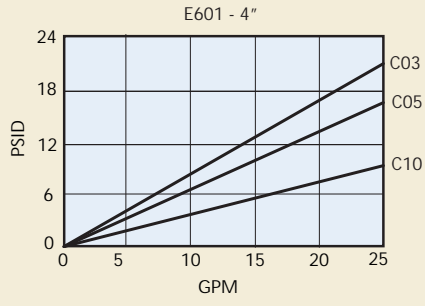

HIGH PRESSURE SPIN-ON FILTERS
 LOW PRESSURE SPIN-ON FILTERS
 IN-TANK FILTERS
 LOW PRESSURE FILTERS
 MEDIUM PRESSURE FILTERS
 HIGH PRESSURE FILTERS

Filter Assembly	W610 TABLE 1	1 TABLE 2	A TABLE 3	4 TABLE 4	J N TABLE 5	B TABLE 6	1 TABLE 7	C TABLE 8	10 TABLE 9
Service Element	E601 TABLE 1	1 TABLE 2	B TABLE 6	1 TABLE 7	C TABLE 8	10 TABLE 9			

Table 1

Filter Assembly / Service Element	
CODE	DESCRIPTION
W610	Assembly
E601	Element

Table 2

Element Collapse Options	
CODE	DESCRIPTION
1	150 psid for housing w/bypass valve
4	3000 psi for housing w/o bypass valve (H-Pak™ only)

Table 3

Port Size Options	
CODE	PORT SIZE
A	1-1/16" - 12 UN (SAE 12)
B	1-5/16" - 12 UN (SAE 16)
F	1" SAE 4 Bolt Flange Code 61
M	1" SAE 4 Bolt Flange Code 62
S	Manifold Mounting

Table 4

Bypass Setting Options	
CODE	BYPASS SETTING
1	Non-bypass
4	50 psid
6	90 psid

Note: Use option 1 code only with 3000 psid collapse filter element.

Table 5 (Primary)

Indicator Style and Setting	
CODE	ΔP INDICATOR STYLE & SETTING
A	Visual indicator 70 psid w/TL and surge
B	Electrical/visual 70 psid w/TL and surge
D	Electrical/visual 35 psid
E	Electrical/visual 100 psid
G	Electrical/visual 35 psid w/TL
I	Visual indicator 70 psid
J	ΔP indicator plug
L	Visual indicator 35 psid
M	Visual indicator 35 psid w/ TL and surge
N	Electrical/visual 35 psid w/12" 3 wire flying lead
O	Visual indicator 100 psid
P	Visual indicator 100 psid w/TL and surge
R	Electrical switch 35 psid
S	Electrical/visual 100 psid w/12" 3-wire flying lead
T	Electrical switch 100 psid
U	Electrical switch 70 psid
V	Electrical/visual 70 psid w/TL
W	Electrical/visual 100 psid w/TL
Y	Electrical/visual 35 psid w/TL and surge
Z	Electrical/visual 100 psid w/TL and surge

TL (thermal lockout)

Table 5 (Secondary)

Receptacle Options	
CODE	ELECTRICAL STYLE
B	Brad Harrison (5-pin)
H	Hirschmann (4-pin)
N	None, for visual ΔP

Table 6

Seal Options	
CODE	MATERIAL
B	Buna N
E	E.P.R.
V	Viton

Table 7

Assembly & Element Length	
CODE (LGTH)	ELEMENT LENGTH
1 (6.75")	4.0"
2 (10.40")	8.0"
4 (14.03")	13.0"

Table 8

Element Code	
CODE	DESCRIPTION
C	(Glass) 03, 05, 10
H	(Glass) 03, 10

Table 9

Media Rating	
CODE	TARGET FLUID CLEANLINESS LEVEL
03	16/14/12 or better
05	18/16/14 or better
10	20/18/15 or better

Note: Information concerning fluid cleanliness codes is on page 6, the Media Grade Selection Guide.

Metric Porting Available

Change W610 to G610
 Porting code A becomes G3/4" ISO 228 BSPP
 Porting code B becomes G1" ISO 228 BSPP
 Porting code F becomes 1" SAE 4 bolt flange with M10 mounting threads
 Porting code M becomes 1" SAE 4 bolt flange with M12 mounting threads

Indicator Switch Schematic Wiring Diagram

Aluminum Electrical Housings

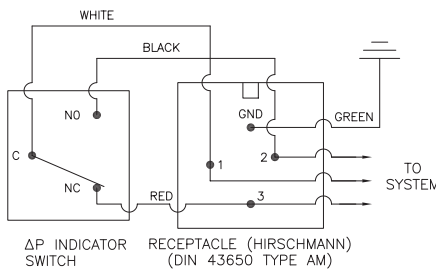
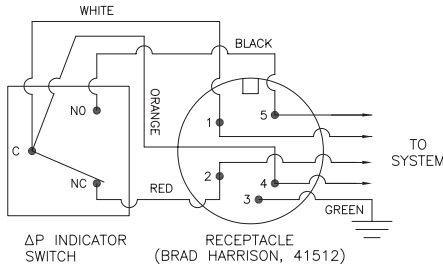

Note: The female plug (connector) is to be furnished by customer.

Plastic Electrical Housings

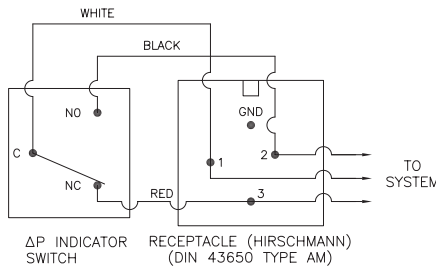
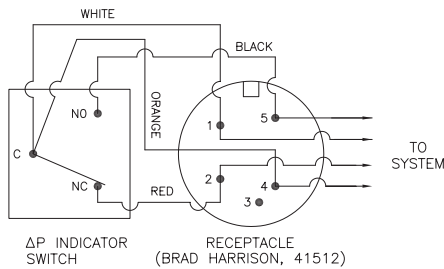

Note: The female plug (connector) is to be furnished by customer.

Dimensions:
millimeters/(inches)

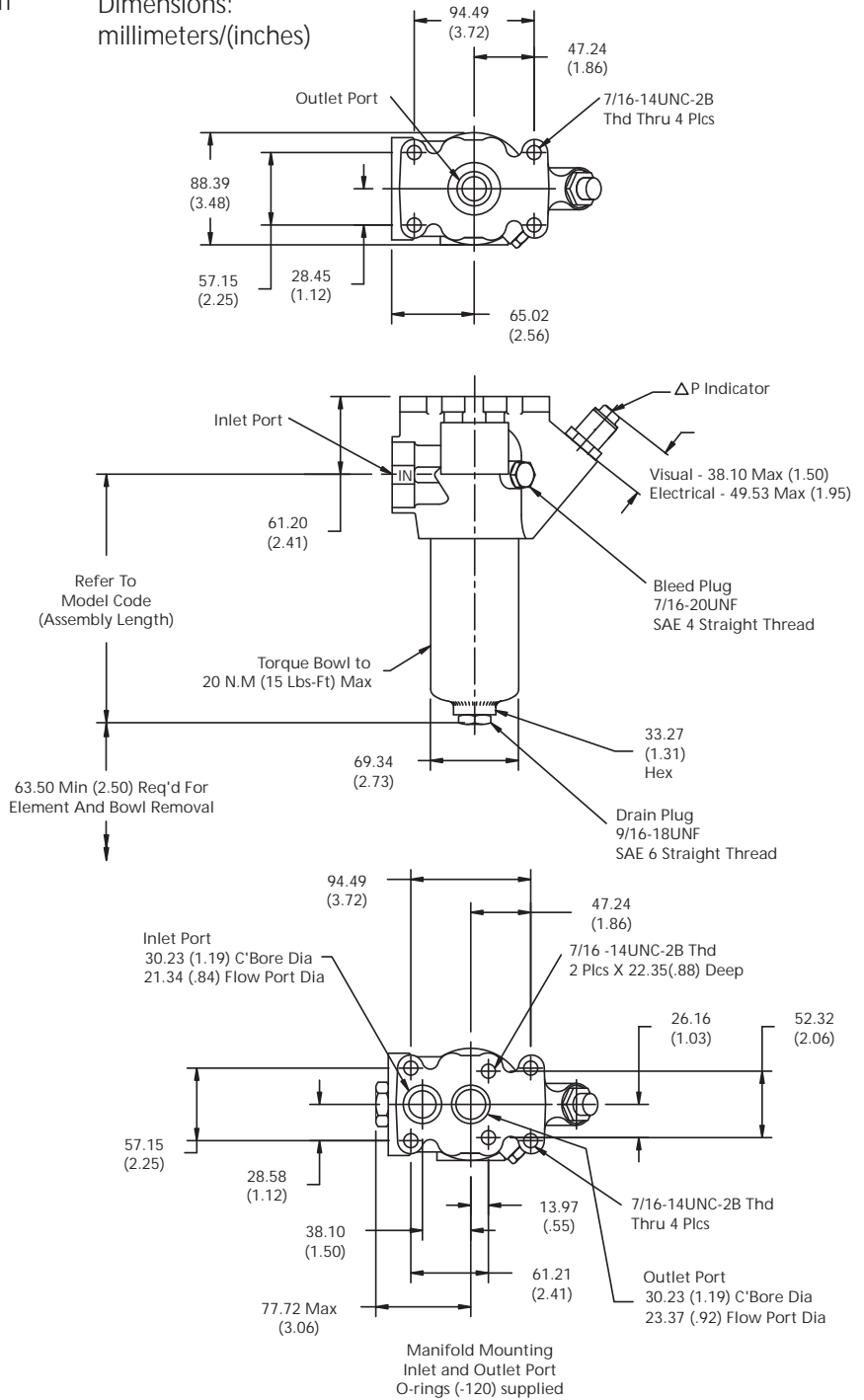

Differential Indicators: Indicators are designed to actuate at approximately 80% of bypass valve cracking pressure. It is recommended that an indicator with a bypass setting of 100 psid is used with a non-bypass housing.

Surge Control: This optional feature is used to dampen pressure surges or spikes to avoid premature actuation of the indicator. Surge control delays the indicator response.

Thermal Lockout: The Thermal Lockout prevents premature signaling of a bypass condition created by viscous fluid during cold start-ups. Normal indicator actuation capability is resumed once the operating temperature of the fluid reaches approximately 80 Deg. F.