



COMPRESSED AIR FILTER ULTRA-FILTER



Innovative to the Core

Significant Increase in Performance due to new Filtration Technology

Besides electricity, water and gas, compressed air is one of the most commonly utilised energy source. Hence, the following aspects have to be considered in high quality compressed air purification:

- Economic filtration
- Validated performance data according to ISO 12500-1
- Reliable achievement of compressed air quality suitable to the application according to ISO 8573-1:2010

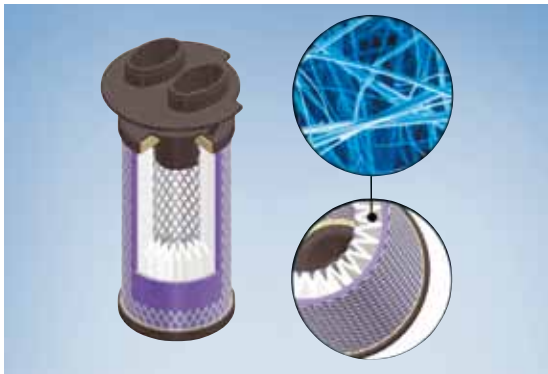

More economic filtration through greater filter surface area and higher dirt retention capacity

The core of each filtration system is the filter element. The new filter medium, advanced production technology and optimised pleating resulted in a reduction of pressure loss by 50 % with increased separation efficiency at the same time. The filter surface area was enlarged by a multiple, ensuring a higher dirt retention capacity.

Unrivalled high Performance

The Ultra-Filter was developed on the basis of world-wide experiences and innovative designs for highly efficient and economic filtration technology.

- A flow-optimised filter design guarantees minimum pressure loss
- The innovative filtration technology ensures high separation efficiency
- An intelligent overall concept for unrivalled efficiency

Computer-aided simulation was the basis for the turbulence-free design with optimised air flow through the filter housing and into the element. This ensures low pressure losses.

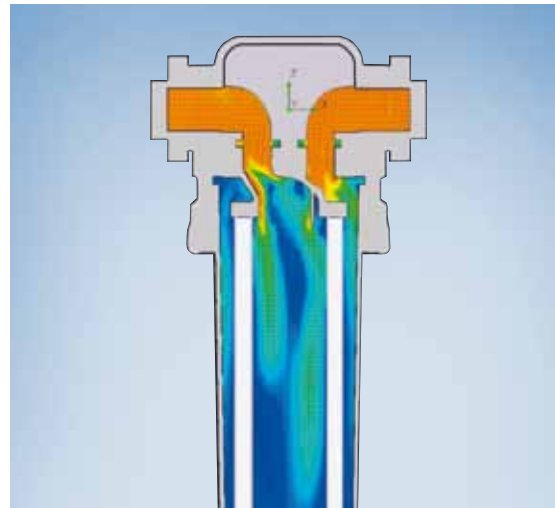

Flow-optimised air flow through a filter housing

Compressed air quality class	Dirt (solid particles)			Water Pressure dew point °C	Oil Concentration mg/m ³
	Maximum particle number per m ³ 0.10 < d ≤ 0.5	particle size, d in µm 0.5 < d ≤ 1.0	1.0 < d ≤ 5.0		
0	Specified according to application and better than Class 1				
1	20,000	400	10	≤ 70	≤ 0.01
2	400,000	6,000	100	≤ 40	≤ 0.1
3	n.s.	90,000	1,000	≤ 20	≤ 1
4	n.s.	n.s.	10,000	≤ +3	≤ 5
5	n.s.	n.s.	100,000	≤ +7	> 5

Compressed air quality according to ISO 8573-1:2010

n.s. = not specified

Cost saving due to Energy Efficiency

Unrivalled Efficiency

The economic efficiency is clearly indicated by the reduction in differential pressure. Just a 200 mbar lower differential pressure over 8,000 operating hours saves 1,500 Euro per year. (7 bar operating pressure, 120 kW installed power, 8 Eurocent/kWh). This practical example shows that the investment in optimizing the compressed air system rapidly pays for itself.

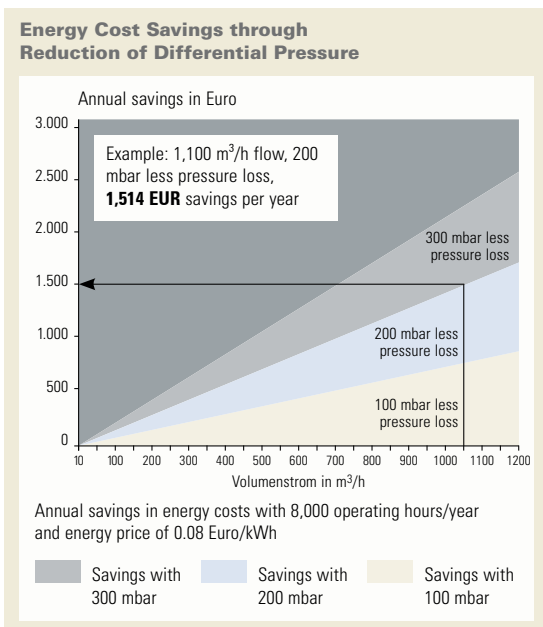

Further energy cost savings are achieved by the timely replacement of used filter elements. The most economic time for this action is determined by the Economizer. This continuously measures the differential pressure. The integrated micro-processor evaluates the measurement data and compares the higher energy costs caused by pressure loss with the costs of a new filter element. The most cost-effective replacement time for the filter element is calculated and LED's then signal that "Filter exchange" is necessary.

Economic efficiency also means: The right filter element for each application. Every required compressed air quality can be achieved with the least possible pressure loss. The Ultra-Filter offers, with its six different grades, all levels from prefilter via sub micro filter to active carbon filter and therefore everything that an efficient compressed air purification needs.

Unrivalled Compactness

The Ultra-Filter is space-saving in every respect:

- The space requirement: up to 30 % less
- The installation height: a few centimetres of ground clearance enables filter exchange
- The installation height: a few centimetres of ground clearance enables filter exchange
- The filter combination: fits into the smallest spaces due to an intelligent adapter solution
- The wall mounting: adjustable

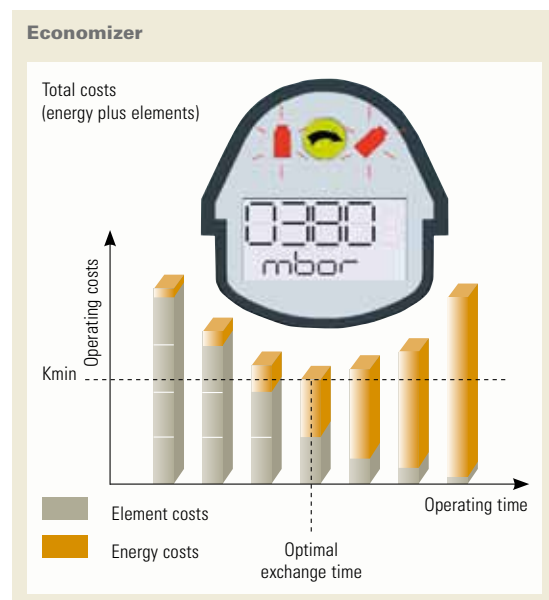

The Economizer shows the most economic time for a filter element exchange

Easy to use

Unrivalled ease of Use

The Ultra-Filter is unrivalled in its ease of use. This is evident both during installation and when the filter element is replaced. The filter bowl is rotated slightly via a bayonet lock and can be removed together with the filter element. The new element is just as easily inserted. The integrated condensate drain does not have to be disconnected from power and condensate feeds. The cover with integrated differential pressure display can be rotated – so that the display stays visible from the selected side.

Unrivalled Flexibility

All filters can be either used as coalescence filters (flow through element from the inside to the outside) or as particulate filters (outside to inside). The essential clue: if requirements change, the filter head does not even have to be rotated. Changing the coding clip inside the filter bowl



The Ultra-Filter is easy to open, because of the bayonet lock

allows the filter element to be rotated and so change the flow direction. The coalescence filter becomes a particulate filter in seconds – and vice versa. Wall supports available on request enable flexible wall mounting. The telescopic design of the support provides stageless adjustability. The combination of filter grades installed in series is provided through connection adapters. Easy to mount and space-saving to even fit into the smallest spaces.



Possible installation in series with connection adapters

Unrivalled Safety

Operating safety is paramount:

- High operating safety through a bayonet lock: The filter cannot be opened while it is under pressure.
- No inflation of coalescence drainage layer: It is completely fixed in place by the outer support sleeve. This ensures a constant flow cross-section between element and housing at all times.
- High quality corrosion protection: All filter housings are immersion-lacquered on the in and outside. This ensures long-term protection, particularly against aggressive condensates.

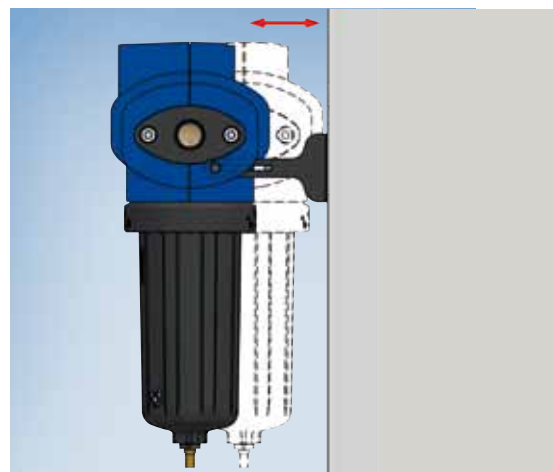

Wall supports enable flexible wall mounting

Unrivalled Variability

Excellence with the Rating "Unrivalled"

With nine sizes, the Ultra-Filter covers the performance range from 35 to 1,100 m³/h flow rate and therefore conventional compressor capacities between 2 and 120 kW.

Three versions are available:

- Standard: Economizer with float drain
- Plus: Economizer with float drain
- Superplus: Economizer with level-controlled condensate drain UFM-D



With the correct selection of the filtration level and flow rate, the right product for the filtration task is always available

P-filter Particle filter	B-filter Particle filter	A-filter Activated carbon filter	V-filter Coalescence filter	M-filter Coalescence filter	S-filter Coalescence filter
Initial differential pressure: 0.15 bar ^A Efficiency: 100% related to 25 µm	Initial differential pressure: 0.12 bar ^A Efficiency: 100% related to 25 µm	Initial differential pressure: 0.15 bar ^A Residual oil content: 0.003 mg/m ³ ^B	Initial differential pressure: 0.11 bar ^A Residual oil content: < 0.2 mg/m ³ ^C	Initial differential pressure: 0.11 bar ^A Residual oil content: < 0.02 mg/m ³ ^C	Initial differential pressure: 0.13 bar ^A Residual oil content: < 0.01 mg/m ³ ^C

^A related to nominal performance at 7 bar, dry condition

^B when upstream connected an M- or S-filter

^C related to an inlet concentration of 3 mg/m³

Technical Data

	Filter type	Capacity*	Connection	Filter element
		Nominal m ³ /h	G	Size
<p>Ultra-Filter version "Superplus" shown here</p>		0035	G 1/4"	0035
		0070	G 3/8"	0070
		0120	G 1/2"	0120
		0210	G 3/4"	0210
		0320	G 1"	0320
		0450	G 1 1/4"	0450
		0600	G 1 1/2"	0600
		0750	G 2"	0750
		1100	G 2"	1100

* related to the intake compressor +20 °C, 1 bar abs., at 7 bar g operating pressure

The new Three-Stage Filter

Unrivalled space-saving

The three-stage filter expands the proven Ultra-Filter series. It will be used for the purification of compressed air or gases when limited space is required. By combining of several purification stages in only one filter housing the DF-T is a very compact solution. It can be used as terminal filter, where the highest quality of compressed air is necessary and only small place for installation is available.

The "All-in-One"-Filter:

- Coalescence filter for the removal of oil aerosols and particles
- Activated carbon adsorber (packed bed) for the removal of oil vapours and other hydrocarbons
- High performance particle filter to achieve the quality class 1 according to ISO 8573-1:2010



Innovative solution in smallest places with the three-stage filter DF-T

The use of the new DF-T filters is as interesting for point of use filtration in sensitive applications, such as the food production, the pharmaceutical industry, in laser cutting machines, as well as environmental technology as in the central compressed air treatment for performances up to 110 m³/h. The filter can be used especially advantageously as a compact treatment unit for small compressors, in order to generate pure compressed air in a simple way, for example in paint applications.

The three-stage filter thereby enables the optimum adjustment of the compressed air quality to the consumer profile as requested by the users.



Cross-section of an Ultra-Filter with DF-T element

Features

- Combination of sub micro filter, activated carbon adsorber and high performance particle filter (compressed air quality class 1)
- Three purification stages in one filter (space savings up to 60 % to traditional solutions)
- Reliable monitoring of the service lifetime of the filter element as well as the differential pressure
- Flow-optimised design
- Perfectly meets the requirements for the use as a terminal filter: Size range, filtration grades, integrated monitoring functions and a reliable working pneumatic condensate drain
- Low pressure losses, thereby saving of energy costs
- Filter cannot be opened under pressure due to bayonet lock

The „All-in-One“-Filter

Safety and Efficiency requires only minimal Space

The Economizer integrated in the filter housing supervises the service lifetime of the filter element and signals the necessary exchange at expiration of the specified time of use. Optional the Economizer supervises the differential pressure of the filter and signals with reaching the adjusted limit that an exchange of the filter element is rational. As the Economizer signals alarm at oil breakthrough it is an ideal solution to protect downstream equipment.

With three sizes the three-stage filter covers the performance range up to 110 Nm³/h flow rate at an operating pressure of 7 bar.



The DF-T is available in three sizes: T0050, T0110, T0080 (f.l.t.r.)

Filter Element

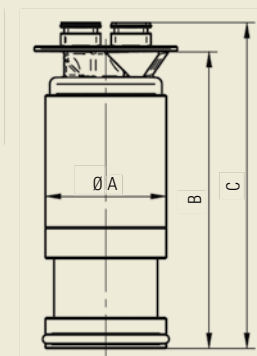

Filter Housing

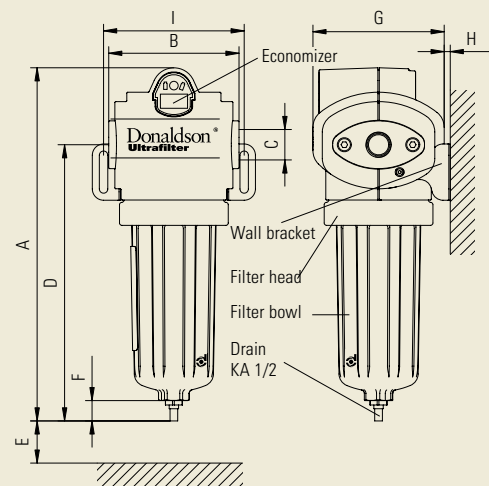

Technical Data DF-T

Size	Flow rate*	Weight **	Housing type	Dimensions housing								Dimensions element			
				A	B	C	D	E	F	G	H	A	B	C	
DF-T	m ³ /h	kg	DF	mm	mm		mm	mm	mm	mm	mm	min./max. mm	mm	mm	mm
0050	50	1.0	0120	341	103	G 1/2"	266	150	27	107	5/34	107	55	135.5	149
0080	80	2.0	0210	382	139	G 3/4"	300	180	27	140	5/53	150	75	157.5	174
0110	110	2.2	0320	442	139	G 1"	360	250	27	140	5/53	150	75	217.5	234

*Nominal flow at 7 bar g, m³/h related to 1 bar abs. and 20 °C **without filter element

Always at your Disposal

Service with the highest Standards

Our service is always nearby. With our technical service and support network throughout Europe, we can routinely service your production systems as well as provide on-site support whenever needed.



With one of Donaldson's service centers you receive quick and cost-effective competent services for all filtration applications from one source.

Consulting

Total Filtration Service offers a range of services to help you determine current production efficiencies, identify areas for improvement and tailor a service program to your needs.

Inspection & Maintenance

Our service experts identify cost-effective measures for process optimisation, quality improvement and energy savings. They conduct emission measurements, leakage detection and comprehensive quality checks and not only carry out the replacement of your filter elements, but also determine the right point in time – we therefore contribute to the efficiency of your production.

Donaldson[®]
Ultrafilter

Compressed Air Filtration · Sterile Filtration · Process Filtration · Refrigerant Drying · Adsorption Drying · Condensate Drains · Condensate Purification Systems · Process Air and Gas Processing



Donaldson[®]
FILTRATION SOLUTIONS

Total Filtration Management

Donaldson offers a wide variety of solutions to reduce your energy costs, improve your productivity, guarantee production quality and help protect the environment.

Total Filtration Service

A comprehensive range of services especially designed to keep your production at peak performance and at the lowest total cost of ownership.

Please contact us:

Donaldson Europe B.V.B.A.

Research Park Building No. 1303 · Interleuvenlaan 1

B-3001 Leuven · Belgium

Phone +32(0)16 38 38 11 · Fax +32(0)16 40 00 77

CAP-europe@donaldson.com · www.donaldson.com