

**A High Efficiency  
Emissions Retrofit Solution with  
No Maintenance -  
The Diesel Multi-stage Filter (DMF) Muffler**



The **patented**<sup>1</sup> Donaldson DMF Muffler offers a new level of emission reduction for 1991-2002 model year diesel-powered engines. As a tailpipe solution, this product will reduce your diesel PM emissions up to 60%!

Reduce your total vehicle emissions even more with our **patented**<sup>2</sup> combination - the DMF Muffler and Spiracle™ Crankcase Filtration System.



**DMF Muffler + Spiracle CFS Kits Now Available!**

<sup>1</sup> U.S. Pat. No. 7,340,888

<sup>2</sup> U.S. Pat No. 7,278,259; 7,257,942

# High Efficiency Filtration with No Maintenance

.... our DMF Mufflers DO NOT require routine ash cleaning

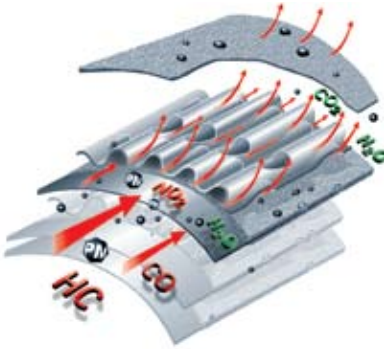

**Partial Flow Through Filter**  
The DMF Muffler uses a two-stage metallic filter to trap and reduce diesel particulate matter (PM). Each filter stage consists of alternating layers of a corrugated metal and a porous sintered metal fleece. The unique catalyst coating reduces PM, HC and CO, while minimizing NO<sub>2</sub> emissions (<20% increase).

## Cut-away view of a Donaldson DMF Muffler

Take-apart design allows easy filter access in the event of an engine failure

Two Corrugated Metal Filter Stages



DMF Muffler  
Patent pending

## Broad Engine Coverage

- Approved for four-stroke on-road diesel engine applications with engine horsepower ranges of 150-600 hp
  - 1991-1993 model year engines (0.25 g/bhp-hr PM or less) with exhaust temperatures of 230° C for 40% of the time and average exhaust temperature of 215° C or above
  - 1994-2002 model engines (0.10 g/bhp-hr PM or less) with exhaust temperatures of 210° C for 40% of time and average exhaust temperature of 210° C or above
- For even more emissions reduction, consider ordering a kit that includes the Donaldson closed crankcase filtration system - Spiracle™ and DMF Muffler.

## Maintenance-Free

- Designed to be maintenance-free. The DMF Muffler does not require ash cleaning.
- Take-apart design allows easy removal of the centerbody (filter) section in the event of an engine failure. Centerbody section is "keyed" to insure proper orientation when reinstalling.

## Compliant

- Verified by CARB to meet Level 2+ (>50% reduction) for the Diesel Risk Reduction Program (DRRP); the '+' designation indicates compliance with CARB and EPA NO<sub>2</sub>/NO<sub>x</sub> limits (<20% increase)
- Reduces diesel particulate matter (PM) up to 60% (and more with the addition of a Spiracle CFS)
- Meets U.S. Federal noise regulations
- Meets engine manufacturer backpressure limits

## Acceptable Fuel Types

- Ultra Low Sulfur Diesel (ULSD - < 15 ppm sulfur)
- BioULSD – maximum B20 blend (20% biodiesel/80% ULSD diesel). Biodiesel blend stock must meet ASTM D 6751 and blend with ASTM D 975 (1-D or 2-D)

## Durable and Warranted

- Meets U.S. EPA and CARB DRRP warranty requirements
- Constructed of aluminized-409 grade stainless steel for strength and corrosion resistance

## Engineered for Performance

- Patented flow distribution devices<sup>1</sup> enhance catalyst performance, deliver uniform airflow and temperatures across the catalyst, and reduce exhaust backpressure



High horsepower engines (>300 HP) may require two (dual) DMF Mufflers to accommodate engines with higher exhaust flow and backpressure. The image on the left is an example of dual DMF application in South America.

## Pre-Selection Requirement

Data logging a vehicle under normal operating duty cycle is the key to reliable DMF Muffler operation.

The Donaldson data logger is a device temporarily installed on a vehicle to collect vehicle/engine exhaust temperature data.

The collected data is reviewed by Donaldson engineers who will determine if a DMF Muffler is the right solution for the vehicle.



Donaldson data logger kit X007947. Software and link-up cable, X007948)

## DMF Muffler Kits and Service Parts

Product selection is based on exhaust flow and current muffler style.

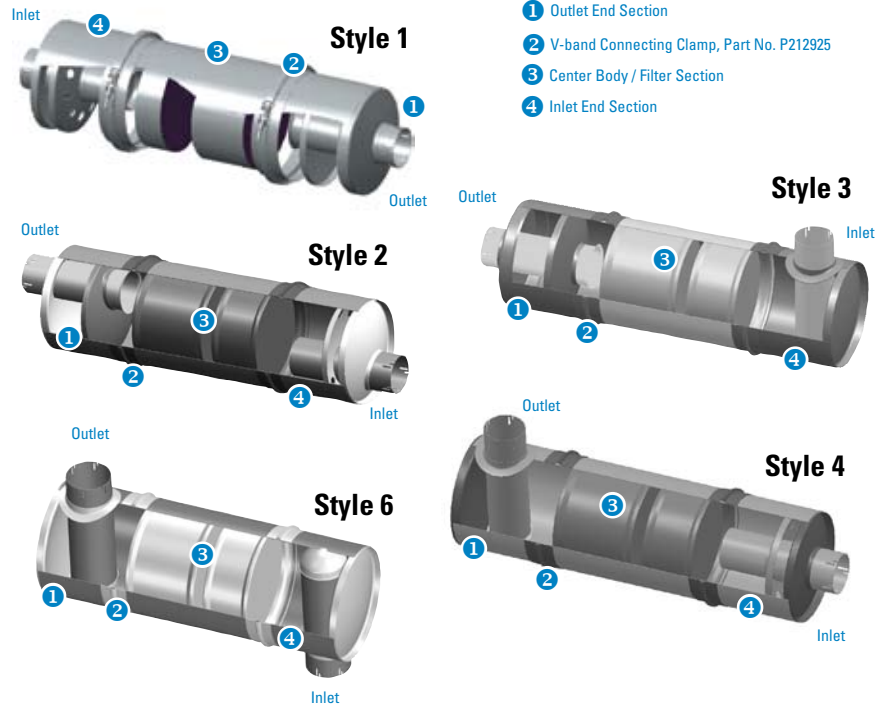

## Need a School Bus Retrofit Kit?



We offer DMF Muffler kits (with mounting hardware) and DMF Muffler + Spiracle CFS Kits are for popular school bus makes including: AmTran, Bluebird, Carpenter, Ford (vans), International and ThomasBuilt.

Call your local emissions dealer or go to the product literature section of our Emissions+Exhaust web site search for Doc. No. F111150.

## DMF Muffler Selection

Now Available!

Inlet I.D.	Outlet I.D.	Overall Length	Body Dia.	--- Available Models ---		-- DMF Muffler Service Parts --		
				DMF Muffler	DMF Muffler + Spiracle CFS	Inlet Section	Outlet Section	Center Body
<b>&lt; 1600 CFM (~300 HP)</b>								
<b>Style 1</b>								
4.0"	4.0"	36.0"	11.0"	X009401	X009703	P226335	P229002	P228434
	5.0"	36.0"	11.0"	X009402	X009704	P226335	P229006	P228434
5.0"	5.0"	36.0"	11.0"	X009403	X009705	P226336	P229006	P228434
<b>Style 2</b>								
3.5"	4.0"	36.0"	11.0"	X009410	X009706	P227630	P229032	P228434
4.0"	4.0"	36.0"	11.0"	X009404	X009707	P227240	P229032	P228434
5.0"	5.0"	36.0"	11.0"	X009408	X009708	P229007	<b>P230861</b>	P228434
<b>Style 3</b>								
4.0"	4.0"	36.0"	11.0"	X009406	X009709	P226339	P229002	P228434
	5.0"	34.0"	11.0"	X009412	X009710	P230893	P230891	P228434
	5.0"	36.0"	11.0"	X009411	X009711	P226339	P229006	P228434
5.0"	5.0"	36.0"	11.0"	X009409	X009712	P229003	P229006	P228434
<b>Style 4</b>								
3.5"	4.0"	36.0"	11.0"	X009407 <sup>(3)</sup>	X009713	P227630	P229033	P228434
4.0"	4.0"	36.0"	11.0"	X009405	X009714	P226335	P229033	P228434
<b>1600-2700 cfm (300-500 hp)</b>								
<b>Style 1</b>								
5.0"	5.0"	36.0"	13.0"	X009364	X009365	P229849	P231731	P231727
<b>Style 2</b>								
5.0"	5.0"	36.0"	13.0"	X009366	X009367	P231928	P232018	P231727
<b>Style 3</b>								
5.0"	5.0"	36.0"	13.0"	X009368	X009369	P229852	P231731	P231727
<b>Style 4</b>								
5.0"	5.0"	36.0"	13.0"	X009370	X009371	P229849	P232014	P231727
<b>Style 6</b>								
5.0"	5.0"	36.0"	13.0"	X009372	X009373	P229852	P232014	P231727

3 Inlet offset from center position

## DMF Muffler Mounting Hardware

A Donaldson Emissions Hardware and Mounting Accessories brochure is viewable from [www.donaldsonexhaust.com](http://www.donaldsonexhaust.com). See the Product Literature or search for document F111200.

Donaldson recommends replacing any original mounting hardware with new, heavy-duty versions. The addition of catalyzed substrate increases the overall weight and requires heavier-duty mounting bands and clamps. Donaldson recommends using two new mounting brackets and SealClamps™ for a DMF Muffler installation.

- Reuse existing frame mounting bolts
- Materials are either zinc-plated or aluminized mild steel.
- Emissions accessories are more durable compared to standard OE exhaust system components on pre-2007 vehicles.

## Spiracle™ Crankcase Filtration System

The Donaldson Spiracle Crankcase Filtration System eliminates 100% of engine crankcase emissions and is a great solution to reduce emissions caused by idling. Independent studies have also found Spiracle CFS improves in-cabin air quality.<sup>4</sup>

Spiracle CFS requires a routine filter maintenance change.

Donaldson Spiracle™ Crankcase Filtration System is protected internationally by patents, both issued and pending.



### Generic Spiracle CFS Retrofit Kit

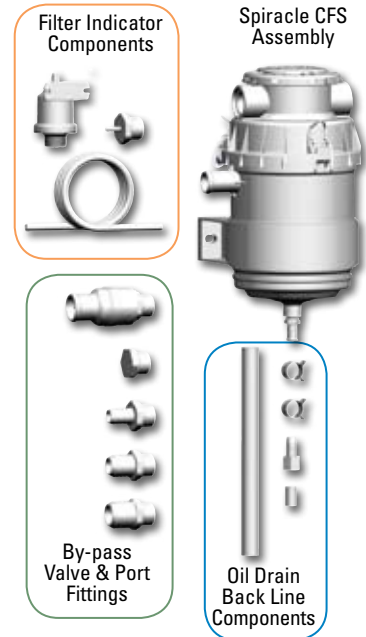

4 - The complete published report, *A Safer Ride to School: How to Clean Up School Buses and Protect Our Children's Health*, is at <http://www.catf.us/publications/view/82>. A separate report, *A Case for the Healthy School Buses*, by The Southern Alliance of Clean Energy, which was based on data from the CATF study is at [www.cleanenergy.org/schoolbusreport.com](http://www.cleanenergy.org/schoolbusreport.com)



# Donaldson®

Donaldson Company, Inc.  
Minneapolis, MN  
55440-1299

[www.donaldson.com](http://www.donaldson.com)

#### Brochure No. F111183 (4/09)

© 2006-2009 Donaldson Company, Inc.  
Printed in the U.S.A.

Donaldson Company, Inc. reserves the right to change or discontinue any model or specification at any time and without notice.

**North & South America**  
866-675-2847  
[emissionssales@donaldson.com](mailto:emissionssales@donaldson.com)

**Europe & Middle East**  
32-16-38-3811

**Asia Pacific**  
65-6311-7373

**South Africa**  
27-11-997-6000

**Australia**  
612-4350-2033