

FEATURES

This versatile spin on series is an excellent choice for use in high corrosion environments. The gray iron head construction can be ordered with gauge or ΔP indicator ports. The popular E0211 series spin-on elements interchange with our W015 and W022 filter heads. The double length canister is available in water absorbing media.

Western Filter’s spin-ons fit many competitor heads and are shipped with both a narrow and rectangular gasket. Western Filter elements are compatible with petroleum oils, water glycol, oil-water, HWCF and synthetic fluids.

Technical Data:

Maximum Working Pressure	200 psi (14 bar)	
Rated Burst Pressure	300 psi max (20.7 bar)	
Temperature Range	Operating -45°F to + 225°F (-43°C to + 107°C)	
Head Material	Gray iron head	
Canister Material	Steel	
Seal Material	Buna N	
Weight		
Assembly		
Length 1	7.0 lbs.	(3,2 kg.)
Length 2	8.0 lbs.	(3,6 kg.)
Canister		
Length 1	2.0 lbs.	(0,9 kg.)
Length 2	3.0 lbs.	(1,4 kg.)

W021/23

60 gpm (227 l/min)

Both gauge ports and differential ΔP ports available

Two element lengths - 7" and 11"

Wide choice of service indicators, gauges and switches

Canister interchangeable with other heads

Gray iron corrosion resistant finish

In-line mounting for easy servicing

Available with water removing element



ACCESSORIES

Breather Adapter 1-1/2" NPT P-077002

Housing and Filter Element

Flow versus Pressure Drop

150 SUS (32 cSt.) oil with specific gravity ≤ 0.9

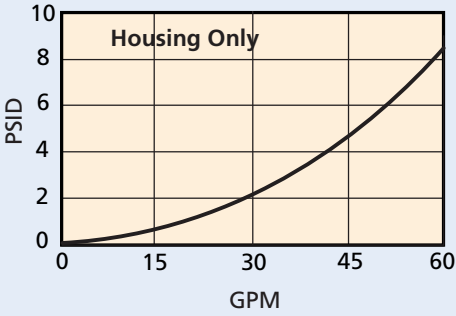

Viscosity Correction Formula

$$\Delta P \text{ Element} = \text{psid from catalog} \times \frac{\text{New Viscosity (SUS)}}{150} \times \frac{\text{New Specific Gravity}}{0.90}$$

$$\Delta P \text{ Housing} = \text{psid from catalog} \times \frac{\text{New Specific Gravity}}{0.90}$$

$$\Delta P \text{ Assembly} = \Delta P \text{ Element} + \Delta P \text{ Housing}$$

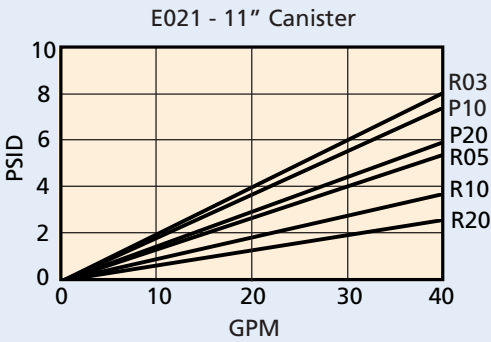
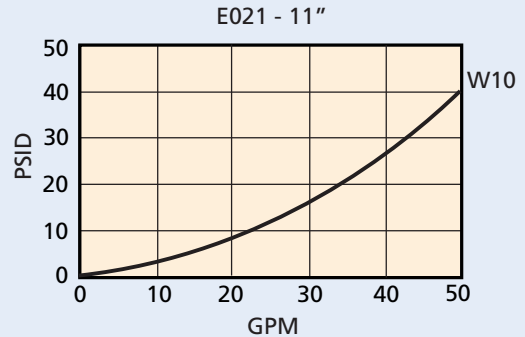
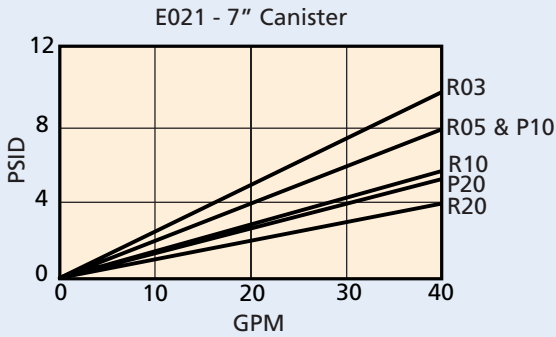

LOW PRESSURE SPIN-ON FILTERS

MEDIUM PRESSURE SPIN-ON FILTERS

IN-TANK FILTERS

LOW PRESSURE FILTERS

MEDIUM PRESSURE FILTERS

HIGH PRESSURE FILTERS

Filter Assembly	W021 TABLE 1	1 TABLE 2	C TABLE 3	3 TABLE 4	4 N TABLE 5	B TABLE 6	1 TABLE 7	R TABLE 8	10 TABLE 9
Service Element	E021 TABLE 1	1 TABLE 2	B TABLE 6	1 TABLE 7	R TABLE 8	10 TABLE 9			

Order model code W0231C4LNB2R10 for same day shipment.

Table 1

Filter Assembly / Service Element	
CODE	DESCRIPTION
W021	Machined for pressure gauge only
W023	Machined for ΔP indicator only
E021	Element

Table 2

Element Collapse Options	
CODE	DESCRIPTION
1	150 psid

Table 3

Port Size Options	
CODE	PORT SIZE
C	1-5/8" - 12 UN (SAE-20)
P	1-1/4" NPT

Table 4

Bypass Setting Options	
CODE	BYPASS SETTING
1	Non-bypassed (plugged)*
3	25 psid
4	50 psid

*80 psid maximum operating pressure

Table 5 (Primary W023 only)

Indicator Style and Setting	
CODE	ΔP INDICATOR STYLE & SETTING
C	Electrical/visual 15 psid
D	Electrical/visual 35 psid
F	Electrical/visual 15 psid & TL
G	Electrical/visual 35 psid & TL
H	Electrical/visual 15 psid with 12" 3-wire flying lead
J	ΔP indicator plug
K	Visual indicator 15 psid
L	Visual indicator 35 psid
M	Visual indicator 35 psid with TL and surge
N	Electrical/visual 35 psid with 12" 3-wire flying lead
Q	Electrical switch 15 psid
R	Electrical switch 35 psid
X	Electrical/visual 15 psid with TL and surge
Y	Electrical/visual 35 psid with TL and surge

TL (thermal lockout)

Table 5 (W021 only)

Upstream Pressure Gauge and Switch Option	
CODE	INDICATOR STYLE & SETTING
1	Gauge ports drilled, tapped and plugged
2	0-200 psi pressure gauge**
3	0-60 psi pressure gauge**
4	0-60 psi pressure gauge*
6	Pressure switch 18 psi Brad Harrison (5-pin)
7	Pressure switch 35 psid Brad Harrison (5-pin)
8	Pressure switch 18 psi Hirschmann (4-pin)
9	Pressure switch 35 psid Hirschmann (4-pin)

*Bypass setting option code 3 only

**Bypass setting option code 4 only

Table 5 (Secondary W023 only)

Receptacle Options	
CODE	ELECTRICAL STYLE
B	Brad Harrison (5-pin)
H	Hirschmann (4-pin)
N	None, for visual ΔP indicator

Table 6

Seal Options	
CODE	MATERIAL
B	Buna N

Table 7

Assembly & Element Length	
CODE (LGTH)	CANISTER LENGTH
1 (8.62")	7.0"
2 (12.62")	11.0"

Table 8

Element Code	
CODE	DESCRIPTION
P	(Cellulose) 10, 20
R	(Glass) 03, 05, 10, 20
W	(Water absorbent) 10 <i>canister length 2 (11") only</i>

Table 9

Media Rating	
CODE	TARGET FLUID CLEANLINESS LEVEL
03	16/14/12 or better
05	18/16/14 or better
10	20/18/15 or better
20	22/19/16 or better

Note: Information concerning fluid cleanliness codes is on page 6, the Media Grade Selection Guide.

Indicator Switch Schematic Wiring Diagram

Dimensions:
millimeters/(inches)

Aluminum Electrical Housings

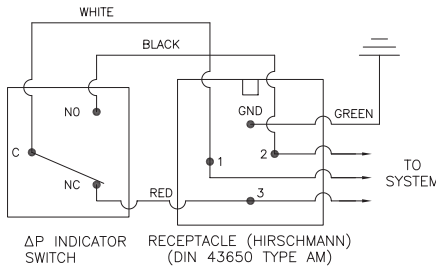
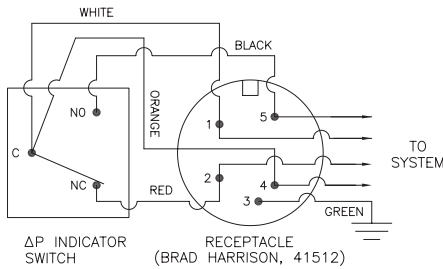

Note: The female plug (connector) is to be furnished by customer.

Plastic Electrical Housings

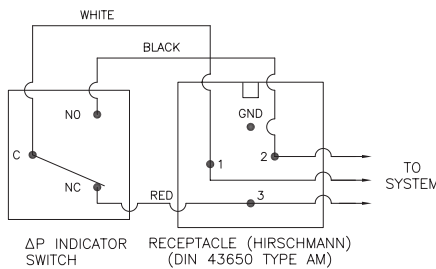
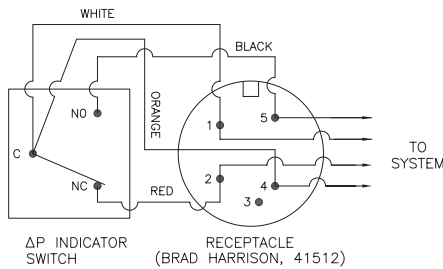

Note: The female plug (connector) is to be furnished by customer.

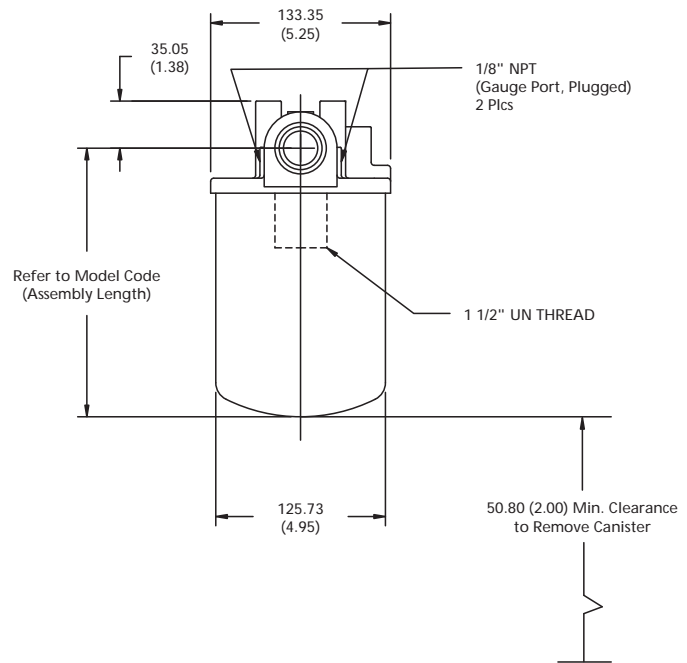
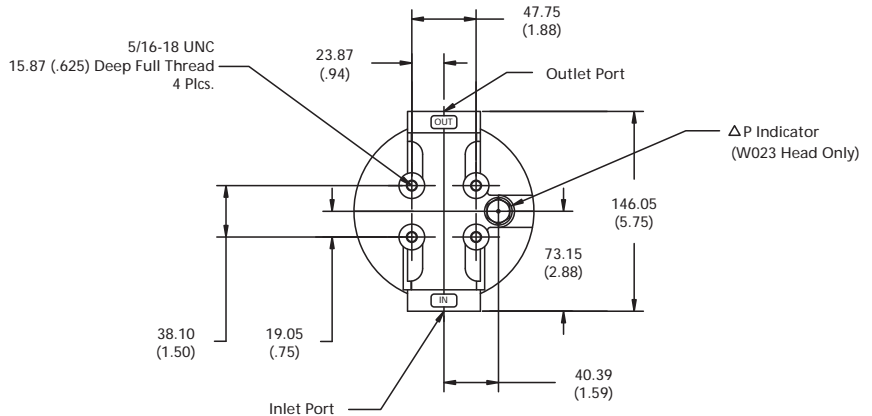

Differential Indicators:

Indicators are designed to actuate at approximately 80% of bypass valve cracking pressure. It is recommended that an indicator with a bypass setting of 100 psid is used with a non-bypass housing.

Surge Control:

This optional feature is used to dampen pressure surges or spikes to avoid premature actuation of the indicator. Surge control delays the indicator response.

Thermal Lockout:

The Thermal Lockout prevents premature signaling of a bypass condition created by viscous fluid during cold start-ups. Normal indicator actuation capability is resumed once the operating temperature of the fluid reaches approximately 80 Deg. F.

LOW PRESSURE SPIN-ON FILTERS

MEDIUM PRESSURE SPIN-ON FILTERS

IN-TANK FILTERS

LOW PRESSURE FILTERS

MEDIUM PRESSURE FILTERS

HIGH PRESSURE FILTERS