

PF-EG stainless steel housing

Stainless steel anticorrosive liquid filter housing

Product description:

PF-EG filter housings have been developed for the filtration of beverages such as beer, wine, mineral water, softdrinks and product-water for many applications. The housings of the PF-EG series are equipped with male thread connection (outlet), coupling nut and liner connection (inlet) acc. to DIN 11851.

Venting of filter housing and mounting of (optional) devices for measurement of integrity or pressure is possible through DN 40 clamp connection at housing top. Numerous different sizes of housings with various connections make it possible to adapt the filter system to exactly the needed requirements.

In this product series there are 12 different sizes of housings for operating volume flows of 3 to 600 l/min, depending on the intended use and the chosen filter element.

The code 7 bajonet-connection guarantees that the elements remain safely fixed at all times.

Due to the Donaldson Ultrafilter modular design different filter elements can be used in a housing as needed.

The range covers prefilters as well as sterile depth- or membrane filters with retention rates up to 0.04 µm.

The clamp connection between upper and lower bowl makes a fast opening and closing possible.

The PF-EG filter housings comply to the requirements of the European directive 97/23/EG for pressure vessels.

Low differential pressure at high flow rates and the milkpipe connections make the PF-EG housing your first choice in applications involving beverage and liquid industries.

The Superplus-housings are equipped with pharma valves at the lowest point of in-and outlet.

The surface is electropolished in-and outside to 0.8 µm.



Technical data

Materials:	
Filter housing:	stainless steel 1.4404
Housing gasket:	EPDM (other gaskets on request)

Design temperature:
180°C

Design pressure:
10 bar

Maximal operating pressure:	
for liquids:	10 bar at 50°C
for saturated steam:	3,7 bar at 150°C
Type 0600:	3 bar at 144°C

Maximum operating temperature:
Depends on the filter element and the sealing of the housing, up to 180°C

Surface finish:
Inner and outer:
Standard 0012-0600 : etched and passivated
Superplus 0003-0600: electropolished $R_a < 0,8 \mu\text{m}$

Connections:
Milkpipe acc. to DIN 11851 (Standard)
Inlet: coupling nut and liner connection
Outlet: male thread connection
Other connections on request

Process filter PF-EG 0003-0075 with milkpipe connection

Pos.	Piece	Description
9	1	filter element (Code 7 connection)
8	1	clamp gasket
7	1	clamp fastener
6	1	clamp blind flange
5	3	leg
4	1	lower housing bowl
3	1	clamp gasket
2	1	clamp fastener
1	1	upper housing bowl

Max. operating pressure for liquids:	10 bar at min./ max. operating temperature +1°C / 50°C
Max. operating pressure for saturated steam:	3.7 bar at operating temperature 150°C
Design temperature housing:	180°C
Test pressure:	14.3 bar
Material housing:	1.4404
Material attaching parts:	1.4301
Surface finish Standard:	etched and passivated
Surface finish Superplus:	inner and outer electropolished $R_a < 0.8 \mu\text{m}$

Classification acc. to 97/23/EG for fluids of group 2	
PF-EG 0003-0075	Art. 3, par. 3

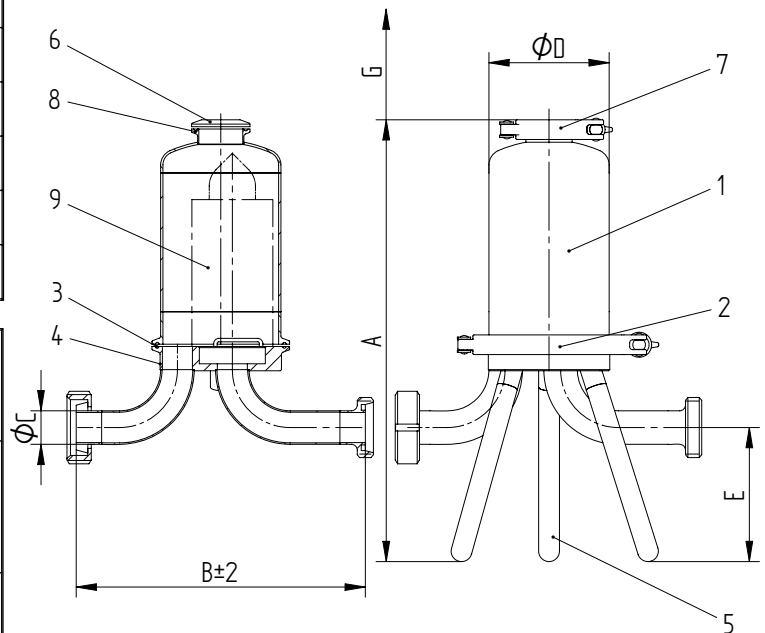

Size	Volume (l)	Weight* (kg)	A mm	B mm	C mm	D	E mm	G mm	Element
0003	0.3	1.4	280	180	DN 10 / \varnothing 17,2	DN 65	100	90	03/10
0012	1.5	5.8	375	250	DN 25 / \varnothing 29	DN 100	106	150	5/3 Code 7
0025	2.5	6.5	505	250	DN 25 / \varnothing 29	DN 100	106	280	10/3 Code 7
0050	4.5	7.7	765	250	DN 25 / \varnothing 29	DN 100	106	580	20/3 Code 7
0075	6.6	9.1	1025	250	DN 25 / \varnothing 29	DN 100	106	850	30/3 Code 7

* without filter element, legs included

Process filter PF-EG 0080-0600 with milkpipe connection

Pos.	Description
13	filter element (code 7 connection)
12	tension nut
11	spring
10	bracket plate
9	tie rod
8	clamp gasket
7	clamp fastener
6	clamp blind flange
5	leg
4	lower housing bowl
3	clamp gasket
2	clamp fastener
1	upper housing bowl

Max. operating pressure for liquids:	10 bar at min./ max. operating temperature +1°C / 50°C
Max. operating pressure for saturated steam:	3.7 bar at operating temperature 150°C (Type 0600: 3 bar at 144°C)
Design temperature housing:	180°C
Test pressure:	14.3 bar
Material housing:	1.4404
Material attaching parts:	1.4301
Surface finish Standard:	etched and passivated
Surface finish Superplus:	inner and outer electropolished $R_a < 0.8 \mu\text{m}$

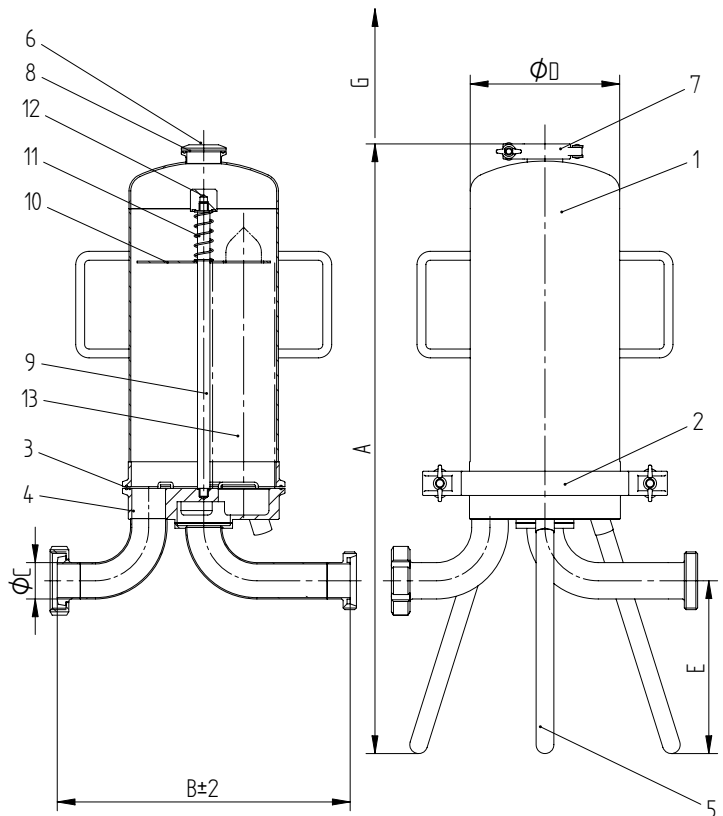

Classification acc. to 97/23/EG for fluids of group 2	
PF-EG 0080-0150	Art. 3, par. 3
PF-EG 0225-0600	Cat. I

Size	Volume (l)	Weight* (kg)	A mm	B mm	C mm	D	E mm	G mm	Element
0080	8.1	16.0	690	330	DN 40 / \varnothing 41	DN 150	194	280	3x10/3 Code 7
0150	12.9	18.3	935	330	DN 40 / \varnothing 41	DN 150	194	580	3x20/3 Code 7
0225	18.6	20.8	1205	330	DN 40 / \varnothing 41	DN 150	194	850	3x30/3 Code 7
0250	23.3	24.0	965	400	DN 50 / \varnothing 53	DN 200	168	580	5x20/3 Code 7
0375	32.5	27.0	1215	400	DN 50 / \varnothing 53	DN 200	168	850	5x30/3 Code 7
0400	46.5	36.9	985	500	DN 65 / \varnothing 70	DN 300	178	580	8x20/3 Code 7
0600	64.2	41.3	1235	500	DN 65 / \varnothing 70	DN 300	178	850	8x30/3 Code 7

* without filter element, legs included